

WIRING DIAGRAM

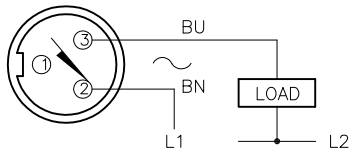

OUTPUT: ADZ30X2

SHORT-CIRCUIT AND OVERLOAD PROTECTED

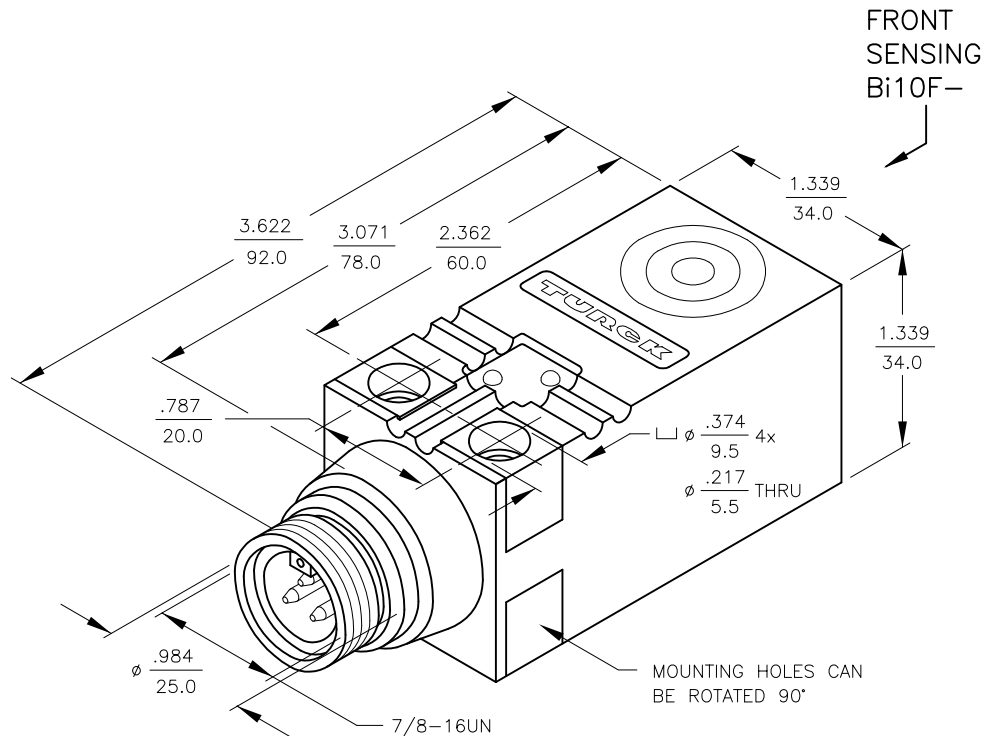

SPECIFICATIONS

OPERATING VOLTAGE	20-250 VAC/DC
LINE FREQUENCY	40-60 Hz
DIFFERENTIAL TRAVEL (HYSTERESIS)	3-15% (5% TYPICAL)
VOLTAGE DROP ACROSS CONDUCTING SENSOR	≤ 6.0 V at 400 mA
OUTPUT FUNCTION	NORMALLY OPEN 2-WIRE AC/DC SELF-CONTAINED
SHORT-CIRCUIT PROTECTED	YES
TRIGGER CURRENT FOR OVERLOAD PROTECTION	≥ 500 mA
CONTINUOUS LOAD CURRENT	≤ 400 mA
OFF-STATE (LEAKAGE) CURRENT	≤ 1.7 mA
MINIMUM LOAD CURRENT	≥ 3.0 mA
INRUSH CURRENT	≤ 3.0 A (≤ 20 ms/5 Hz)
TIME DELAY BEFORE AVAILABILITY	≤ 80 ms
POWER-ON EFFECT PROTECTION	INCORPORATED
PROTECTION AGAINST TRANSIENTS	5 kV, 10 ms, 10 kΩ
OPERATING TEMPERATURE	-25°C to +70°C (-13°F to +158°F)
ENCLOSURE	MEETS NEMA 1, 3, 4, 6, 13 AND IEC IP67
SHOCK	30 g, 11 ms
VIBRATION	55 Hz, 1 mm AMPLITUDE (IN ALL 3 PLANES)
LED FUNCTION	GREEN = POWER ON GREEN FLASHING = SHORT-CIRCUIT WARNING RED = OUTPUT ENERGIZED
RATED OPERATING DISTANCE(S _n)	10 mm = .394" (NOMINAL)
SWITCHING FREQUENCY	30 Hz
REPEATABILITY	≤ 2% of RATED OPERATING DISTANCE
EMBEDDABLE (SHIELDED)	YES

NOTES:

1. "/S34" DESIGNATES WELD FIELD IMMUNITY. SENSOR IS SUITABLE FOR USE ON RESISTANCE WELDING MACHINES.

RELATED DOCUMENTS 1. 2. 3. 4.	3RD ANGLE PROJECTION 	THIS DRAWING IS CONFIDENTIAL AND THE PROPERTY OF TURCK INC. USE OF THIS DOCUMENT WITHOUT WRITTEN PERMISSION IS PROHIBITED.		3000 CAMPUS DRIVE MINNEAPOLIS, MN 55441 1-800-544-7769 (763) 553-7300 (763) 553-0708 fax www.turck.us	
	MATERIAL	DRFT SMW	DATE 9/2/86	DESCRIPTION Bi10F-Q34-ADZ30X2-B1131/S34	
FINISH	ALL DIMENSIONS DISPLAYED ON THIS DRAWING ARE FOR REFERENCE ONLY	APVD	SCALE NONE	IDENTIFICATION NO. 4201100	
	CONTACT TURCK FOR MORE INFORMATION	UNIT OF MEASUREMENT INCH [MILLIMETER]		REV F	
F	UPDATE ID NUMBER PER HARMONIZATION PROJECT	CBM	01/02/18	DO NOT SCALE THIS DRAWING	
REV	DESCRIPTION	BY	DATE	ECO NO.	FILE: 4201100
					SHEET 1 OF 1